

NOTES:

1. METAL IS UNS S31603/AISI 316L PER ASTM A276.
2. O-RING MATERIAL IS EPDM.
3. MAXIMUM WORKING PRESSURE = 20 BAR (290 PSI).
4. BURST PRESSURE RATING = 80 BAR (1160 PSI).
5. TEMPERATURE RATING = -40°C TO 120°C (-40°F TO 248°F).
6. TORQUE THREAD TO 35 N-M (310 IN-LB).
7. A BLUE OR RED RING IS LOCATED HERE.
8. FORCE TO CONNECT UNDER NO PRESSURE = 70 N (15.7 LBF).
9. MAXIMUM FLOW RATE = 84 LPM (22.2 GPM).
10. FLOW COEFFICIENT = 5.15.
11. MAXIMUM FLUID LOSS = <0.025 ML (0.39 DROP).

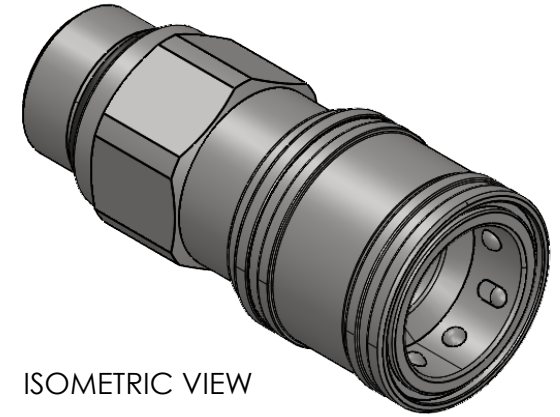

ISOMETRIC VIEW

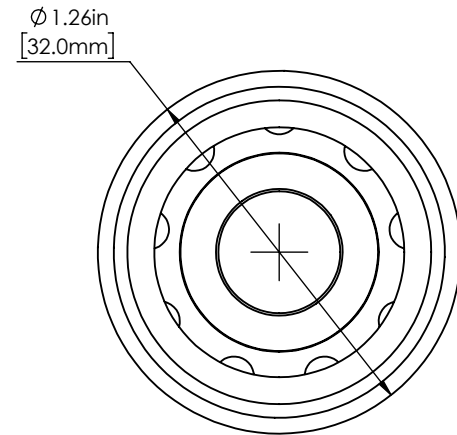
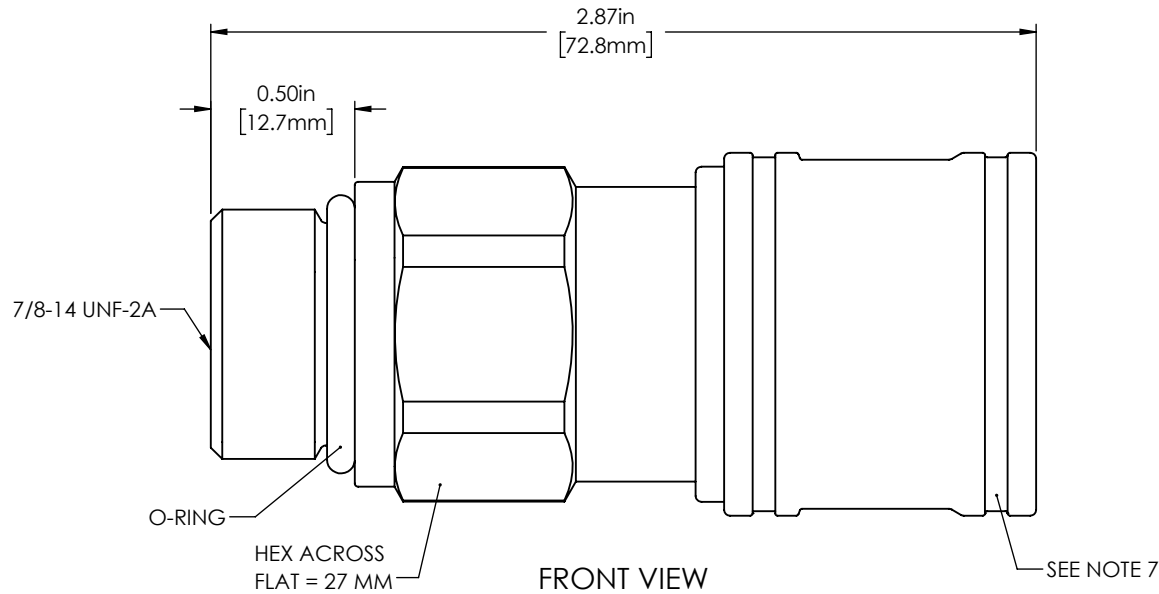

RIGHT END VIEW

UNLESS OTHERWISE SPECIFIED:  
 DIMENSIONS ARE IN INCHES.  
 BREAK ALL SHARP EDGES .005 MAX.  
 TOLERANCES:  
 ANGULAR: ±0.5°  
 TWO PLACE DECIMAL: ±0.010"  
 THREE PLACE DECIMAL: ±0.005"  
 DIAMETERS: 0.006" TIR ABOUT Q  
 MAXIMUM SURFACE ROUGHNESS: Ra 90 µin

MATERIAL: SEE NOTES 1 AND 2  
 HEAT TREATMENT: N/A  
 SURFACE FINISH: N/A

	NAME	DATE
DRAWER	TONY HEPP	6-16-2026
ENG APPR.	TONY HEPP	6-16-2026
MFG APPR.	MIKE RUSSELL	6-17-2026



2324 W. Battlefield Rd. Springfield, MO 65807

TITLE:  
 UNIVERSAL QUICK DISCONNECT,  
 BODY SIZE 08 / 1/2",  
 FEMALE SOCKET,  
 MALE ORB 7/8-14 UNF

SIZE <b>A</b>	DWG. NO. UQD08F-SM70U	REV <b>A</b>
------------------	--------------------------	-----------------

THEORETICAL WEIGHT 7.46	SCALE:	SHEET 1 OF 1
----------------------------	--------	--------------

**PROPRIETARY AND CONFIDENTIAL**

THE INFORMATION DISCLOSED IN THIS DOCUMENT IS PROPRIETARY TO FOSTER MFG. CO. AND MAY NOT BE USED FOR MANUFACTURE OR ANY OTHER PURPOSE WITHOUT THE WRITTEN CONSENT OF FOSTER MFG CO.